

Optidrive Plus 3^{GV} Compact

OEM AC Variable Speed Drive
0.75 – 1.5kW (1 – 2HP)



Invertek Drives Ltd hereby states that the Optidrive Plus 3^{GV} product range is CE marked for the low voltage directive and conforms to the following harmonised European directives:

EN 61800-5-1: 2003	Adjustable speed electrical power drive systems. Safety requirements. Electrical, thermal and energy.
EN 61800-3 2 nd Ed: 2004	Adjustable speed electrical power drive systems. EMC requirements and specific test methods
EN 55011: 2007	Limits and Methods of measurement of radio disturbance characteristics of industrial, scientific and medical (ISM) radio-frequency equipment (EMC)
EN60529 : 1992	Specifications for degrees of protection provided by enclosures

CE - Konformitätserklärung:

gemäß den Produktnormen für Drehzahlveränderbare Antriebe, die Firma 'Invertek Drives Ltd., UK erklärt dass das Produkt: Optidrive Plus/VTC (statischer Frequenzumrichter zur Drehzahlregelung von Asynchronmotoren) nach den folgenden harmonisierten Produktnormen entwickelt und gebaut wird:

EN 61800-5-1: 2003	Elektrische Leistungsantriebssysteme mit einstellbarer Drehzahl. Anforderungen an die Sicherheit. Elektrische, thermische und energetische Anforderungen
EN 61800-3 2 nd Ed: 2004	Drehzahlveraenderbare elektrische Antriebe. EMV-Anforderungen einschliesslich spezieller Prueverfahren
EN 55011: 2007	Industrielle, wissenschaftliche und medizinische Hockfrequenzgeraeten (ISM-Geraeten). Funkstoerungen. Grenzwerte und Messverfahren
EN60529 : 1992	Schutzarten durch Gehaeuse (IP Code)

Déclaration de Conformité:

Invertek Drives Ltd déclare par la présente que le produit Optidrive Plus/VTC porte le marquage CE en relation avec la directive basse tension et est conforme aux norms Européennes harmonisées suivantes :

EN 61800-5-1: 2003	Entrainements électriques de puissance à vitesse variable. Exigences de sécurité. Electrique, thermique et énergétique
EN 61800-3 2 nd Ed: 2004	Entrainements électriques de puissance à vitesse variable. Exigences de CEM et méthodes d'essais spécifiques
EN 55011: 2007	Appareils industriels, scientifiques et médicaux (ISM) à fréquence radioélectrique. Caractéristiques de perturbations radioélectriques. Limites et méthodes de mesure
EN60529 : 1992	Degrés de protection procures par les enveloppes (Code IP)

All rights reserved. No part of this User Guide may be reproduced or transmitted in any form or by any means, electrical or mechanical including photocopying, recording or by any information storage or retrieval system without permission in writing from the publisher.

Copyright Invertek Drives Ltd © 2007

All Invertek Optidrives carry a 2 year warranty against manufacturing defects from the date of manufacture. The manufacturer accepts no liability for any damages caused during or resulting from transport, receipt of delivery, installation or commissioning. The manufacturer also accepts no liability for damages or consequences resulting from inappropriate, negligent or incorrect installation, incorrect adjustment of the operating parameters of the drive, incorrect matching of the drive to the motor, incorrect installation, unacceptable dust, moisture, corrosive substances, excessive vibration or ambient temperatures outside of the design specification.

The local sales partner may offer different terms and conditions at their discretion, and in all cases concerning warranty, the local sales partner should be contacted first.

The contents of this User Guide are believed to be correct at the time of printing. In the interest of a commitment to a policy of continuous improvement, the manufacturer reserves the right to change the specification of the product or its performance or the contents of the User Guide without notice.

This User Guide is for use with V3.00 Firmware.

User Guide Issue 1.06 11/08

Invertek Drives Ltd adopts a policy of continuous improvement and whilst every effort has been made to provide accurate and up to date information, the information contained in this user guide should be used for guidance purposes only and does not form the part of any contract

1.	INTRODUCTION	4
1.1.	Important safety information	4
1.2.	Electromagnetic Compatibility (EMC)	4
2.	TECHNICAL DATA	5
2.1.	Environmental	5
2.2.	Rating tables	5
3.	MECHANICAL INSTALLATION	6
3.1.	General	6
3.2.	Mechanical dimensions and mounting	6
3.3.	Enclosure mounting	6
4.	POWER AND CONTROL CONNECTIONS	7
4.1.	Grounding the Drive	7
4.2.	Wiring Precautions	7
4.3.	Connection Diagram	8
4.4.	Drive and motor connections	8
4.5.	Motor Terminal Box Connections	8
4.6.	Control terminal connections	9
5.	OPERATION	9
5.1.	Optional Optiport Plus Keypad	9
5.2.	Changing Parameters	10
5.3.	Advanced Keypad Operation Short Cuts	10
5.4.	Reset All Parameters to Factory Default Settings	10
5.5.	Terminal Control	11
5.6.	Keypad Control	11
5.1.	Motor Autotuning	12
5.2.	Operating in Sensorless Vector Speed Control Mode	12
5.3.	Sensorless Vector Torque Control Mode	12
6.	PARAMETERS	13
6.1.	Parameter Group 1 – Basic Parameters	13
6.2.	Parameter Group 2 - Extended parameters	14
6.3.	Parameter Group 3 – PID Control	16
6.4.	Parameter Group 4 – High Performance Motor Control	17
6.5.	Parameter Group 0 – Monitoring Parameters (Read Only)	17
7.	ANALOG AND DIGITAL INPUT CONFIGURATIONS	18
7.1.	Terminal mode (P1-12 =0)	18
7.2.	Keypad mode (P1-12 = 1 or 2)	19
7.3.	User PI control mode (P1-12 = 3)	19
8.	TROUBLESHOOTING	20
8.1.	Fault messages with optional Optiport Plus Keypad	20



1. Introduction

1.1. Important safety information

This variable speed drive product (Optidrive) is intended for professional incorporation into complete equipment or systems. If installed incorrectly it may present a safety hazard. The Optidrive uses high voltages and currents, carries a high level of stored electrical energy, and is used to control mechanical plant that may cause injury. Close attention is required to system design and electrical installation to avoid hazards in either normal operation or in the event of equipment malfunction.



System design, installation, commissioning and maintenance must be carried out only by personnel who have the necessary training and experience. They must carefully read this safety information and the instructions in this Guide and follow all information regarding transport, storage, installation and use of the Optidrive, including the specified environmental limitations.

Please read the IMPORTANT SAFETY INFORMATION below, and all Warning and Caution information elsewhere.

 WARNING	Indicates a potentially hazardous situation which, if not avoided, could result in injury or death.	 CAUTION	Indicates a potentially hazardous situation which, if not avoided, could result in damage to property.
---	---	--	--

Safety of machinery, and safety-critical applications

The level of integrity offered by the Optidrive control functions – for example stop/start, forward/reverse and maximum speed, is not sufficient for use in safety-critical applications without independent channels of protection. All applications where malfunction could cause injury or loss of life must be subject to a risk assessment and further protection provided where needed. Within the European Union, all machinery in which this product is used must comply with Directive 89/392/EEC, Safety of Machinery. In particular, the electrical equipment should comply with EN60204-1.

 WARNING	<p>Optidrives should be installed only by qualified electrical persons and in accordance with local and national regulations and codes of practice. The Optidrive has an Ingress Protection rating of IP20. For higher IP ratings, use a suitable enclosure.</p> <p>Electric shock hazard! Disconnect and ISOLATE the Optidrive before attempting any work on it. High voltages are present at the terminals and within the drive for up to 10 minutes after disconnection of the electrical supply.</p> <p>Where supply to the drive is through a plug and socket connector, do not disconnect until 10 minutes have elapsed after turning off the supply</p> <p>Ensure correct earthing connections. The earth cable must be sufficient to carry the maximum supply fault current which normally will be limited by the fuses or MCB</p> <p>The STOP function does not remove potentially lethal high voltages. ISOLATE the drive and wait 10 minutes before starting any work on it</p> <p>Parameter P1-01 can be set to operate the motor at up to 120,000 rpm, hence use this parameter with care.</p> <p>If it is desired to operate the drive at any frequency/speed above the rated speed (P1-09/ P1-10) of the motor, consult the manufacturers of the motor and the driven machine about suitability for over-speed operation.</p>
 CAUTION	<p>Carefully inspect the Optidrive before installation to ensure it is undamaged</p> <p>Indoor Use Only.</p> <p>Flammable material should not be placed close to the drive</p> <p>The entry of conductive or flammable foreign bodies should be prevented</p> <p>Relative humidity must be less than 95% (non-condensing).</p> <p>Ensure that the supply voltage, frequency and no. of phases (1 or 3 phase) correspond to the rating of the Optidrive as delivered.</p> <p>An isolator should be installed between the power supply and the drive.</p> <p>Never connect the mains power supply to the Output terminals U, V, W.</p> <p>Suitably rated fuses or MCB should be fitted in the mains supply to the drive.</p> <p>Do not install any type of automatic switchgear between the drive and the motor</p> <p>Wherever control cabling is close to power cabling, maintain a minimum separation of 100 mm and arrange crossings at 90 degrees</p> <p>Ensure that all terminals are tightened to the appropriate torque setting</p>

1.2. Electromagnetic Compatibility (EMC)

The Optidrive Plus 3GV Compact is designed to be mounted in close proximity to the driven motor. Within the European Union, equipment into which this product is incorporated must comply with 89/336/EEC, EMC. It is the responsibility of the installer to ensure that the equipment or system into which the product is incorporated complies with the EMC legislation of the country of use. Drive versions are available fitted with an internal EMC filter, designed to reduce the conducted emissions back into the supply via the power cables for compliance with the harmonised European standards.

Installation must always be carried out by qualified installation engineers, observing good wiring practice such as power and signal cable segregation and correct screening techniques to minimise emissions. Where the unit is remotely mounted from the motor, screened motor cables must be used with the screen bonded to earth through the largest possible surface area at both ends.

The following table gives the maximum motor cable lengths allowed for compliance with the EMC standard for drives fitted with an internal RFI Filter :-

Drive Type		Maximum Motor Cable Length for Emission Classification as defined by EN61800-3:2004		
kW	Volts	C2	C3	C4
0.75	230	Filtered, 1m	Filtered, 1m	10m
1.5	230	Filtered, 1m	Filtered, 1m	10m
0.75	400	Filtered, 1m	Filtered, 1m	10m
1.5	400	Filtered, 1m	Filtered, 1m	10m

2. Technical data

2.1. Environmental

Operational ambient temperature range	: -10 ... 60°C, Frost and condensation free
Storage ambient temperature range	: -40 ... 60°C
Maximum altitude	: 2000m. Derate above 1000m : 1% / 100m
Maximum humidity	: 95%, non-condensing

2.2. Rating tables

200-240V ±10% - 1 Phase Input – 3 Phase Output, Without EMC Filter									
Model (kW)	kW	HP	Nominal Input Current	Fuse or MCB (type B)	Supply Cable Size	Nominal Output Current	150% Output Current 60 secs	Motor Cable Size	Max Motor Cable Length
			Amps	Amps	mm ²	Amps	Amps	mm ²	m
OPC-1-12075-1K012	0.75	1	12.5	16	1.5	4.3	6.4	1	10
OPC-1-12150-1K012	1.5	2	19.3	25	4	7	10.5	1.5	10

200-240V ±10% - 1 Phase Input – 3 Phase Output, With EMC Filter									
Model (kW)	kW	HP	Nominal Input Current	Fuse or MCB (type B)	Supply Cable Size	Nominal Output Current	150% Output Current 60 secs	Motor Cable Size	Max Motor Cable Length
			Amps	Amps	mm ²	Amps	Amps	mm ²	m
OPC-1-12075-1KB12	0.75	1	12.5	16	1.5	4.3	6.4	1	10
OPC-1-12150-1KB12	1.5	2	19.3	25	4	7	10.5	1.5	10

380-480V ±10% - 3 Phase Input – 3 Phase Output Without EMC Filter									
Model	kW	HP	Nominal Input Current	Fuse or MCB (type B)	Supply Cable Size	Nominal Output Current	150% Output Current 60 secs	Motor Cable Size	Max Motor Cable Length
			Amps	Amps	mm ²	Amps	Amps	mm ²	m
OPC-1-14075-3K012	0.75	1	2.9	6	1	2.2	3.3	1	10
OPC-1-14150-3K012	1.5	2	5.4	6	1	4.1	6.1	1	10

380-480V ±10% - 3 Phase Input – 3 Phase Output With EMC Filter									
Model	kW	HP	Nominal Input Current	Fuse or MCB (type B)	Supply Cable Size	Nominal Output Current	150% Output Current 60 secs	Motor Cable Size	Max Motor Cable Length
			Amps	Amps	mm ²	Amps	Amps	mm ²	m
OPC-1-14075-3KA12	0.75	1	2.9	6	1	2.2	3.3	1	10
OPC-1-14150-3KA12	1.5	2	5.4	6	1	4.1	6.1	1	10

3. Mechanical Installation

3.1. General

- Store the Optidrive in its box until required. Storage should be clean and dry and within the temperature range -40°C to $+60^{\circ}\text{C}$
- The Optidrive must be installed in a pollution degree 1 or 2 environment

3.2. Mechanical dimensions and mounting

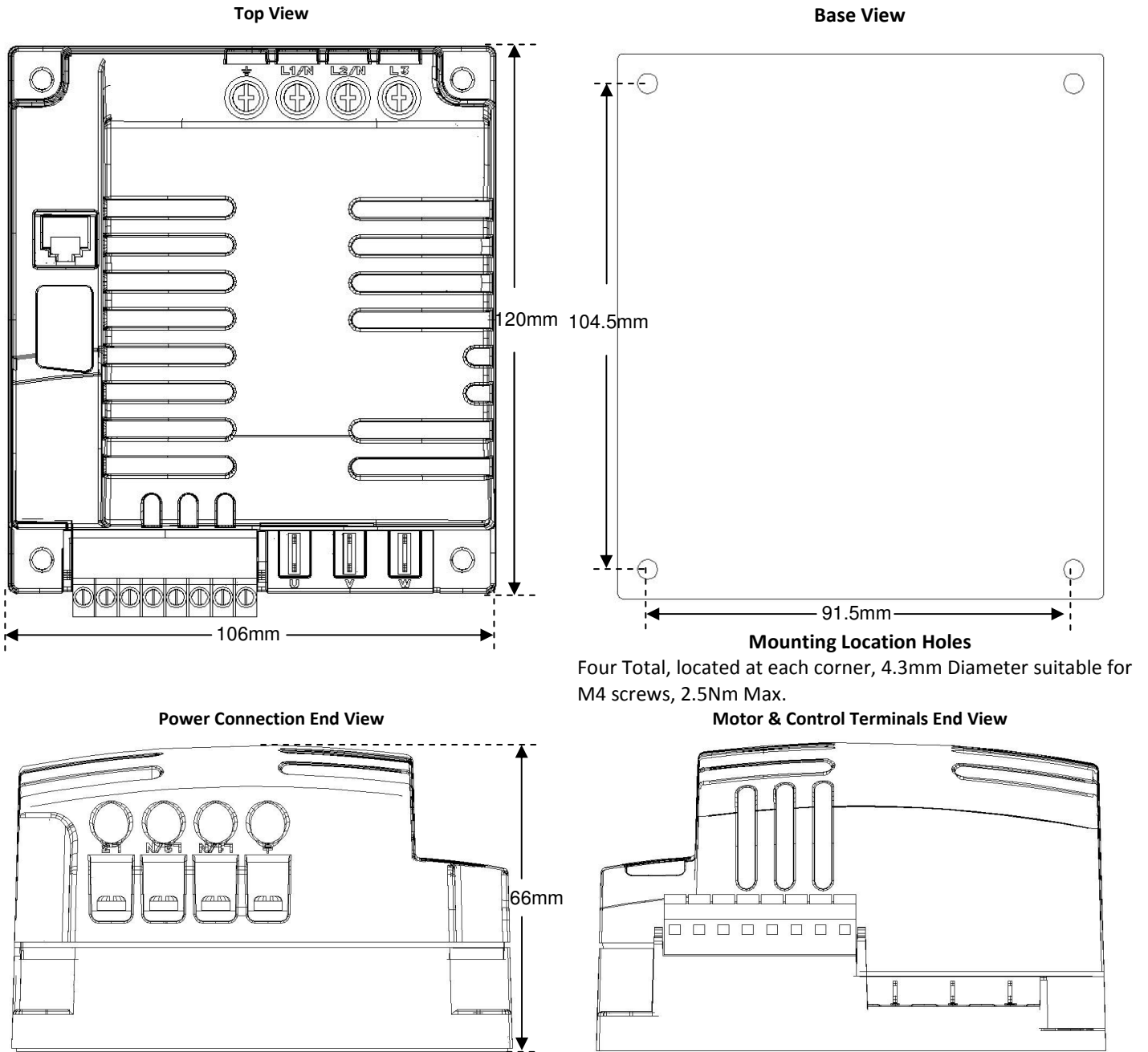

3.3. Enclosure mounting

- The Optidrive Plus 3GV Compact is supplied in an IP20 enclosure, designed to be mounted by the user on a thermally conductive material to dissipate the heat generated by the drive. Typically, this can be a motor or steel control panel.
- The temperature of the heatsink and drive module must be maintained in the range -10 to $+65^{\circ}\text{C}$
- The ambient temperature around the drive must not exceed 60°C
- Typically power losses are approximately 3% of motor absorbed power
- If the external environment contains contamination particles (e.g. dust), the unit should be suitably protected to ensure no damage can occur.
- High moisture, salt or chemical content environments should use a suitably sealed (non-vented) enclosure.

4. Power and Control Connections

4.1. Grounding the Drive



This manual is intended as a guide for proper installation. Invertek Drives Ltd cannot assume responsibility for the compliance or the non-compliance to any code, national, local or otherwise, for the proper installation of this drive or associated equipment. A hazard of personal injury and/or equipment exists if codes are ignored during installation.



This drive contains high voltage capacitors that take time to discharge after removal of main supply. Before working on the drive, ensure isolation of main supply from line inputs. Wait ten (10) minutes for capacitors to discharge to safe voltage levels. Failure to observe this precaution could result in severe bodily injury or loss of life.



Only qualified electrical personnel familiar with the construction and operation of this equipment and the hazards involved should install, adjust, operate, or service this equipment. Read and understand this manual and other applicable manuals in their entirety before proceeding. Failure to observe this precaution could result in severe bodily injury or loss of life.

Grounding Guidelines

Each Optidrive should be individually connected DIRECTLY to the site ground bus bar (through the filter if installed). Optidrive ground connections should not loop from one drive to another, or to, or from any other equipment. Ground loop impedance must conform to local industrial safety regulations. To meet UL regulations, UL approved ring crimp terminals should be used for all ground wiring connections.

The drive Safety Ground must be connected to system ground. Ground impedance must conform to the requirements of national and local industrial safety regulations and/or electrical codes. The integrity of all ground connections should be checked periodically.

Ground Fault Monitoring

If a system ground fault monitor is to be used, only Type B devices should be used to avoid nuisance tripping. An individual device should be used per Optidrive.

Safety Ground

This is the safety ground for the drive that is required by code. One of these points must be connected to adjacent building steel (girder, joist), a floor ground rod, or bus bar. Grounding points must comply with national and local industrial safety regulations and/or electrical codes.

4.2. Wiring Precautions

Connect the Optidrive according to section 4.3, ensuring that motor terminal box connections are correct. There are two connections in general: Star and Delta. It is essential to ensure that the motor is connected in accordance with the voltage at which it will be operated. For more information, refer to section 4.5.

4.3. Connection Diagram

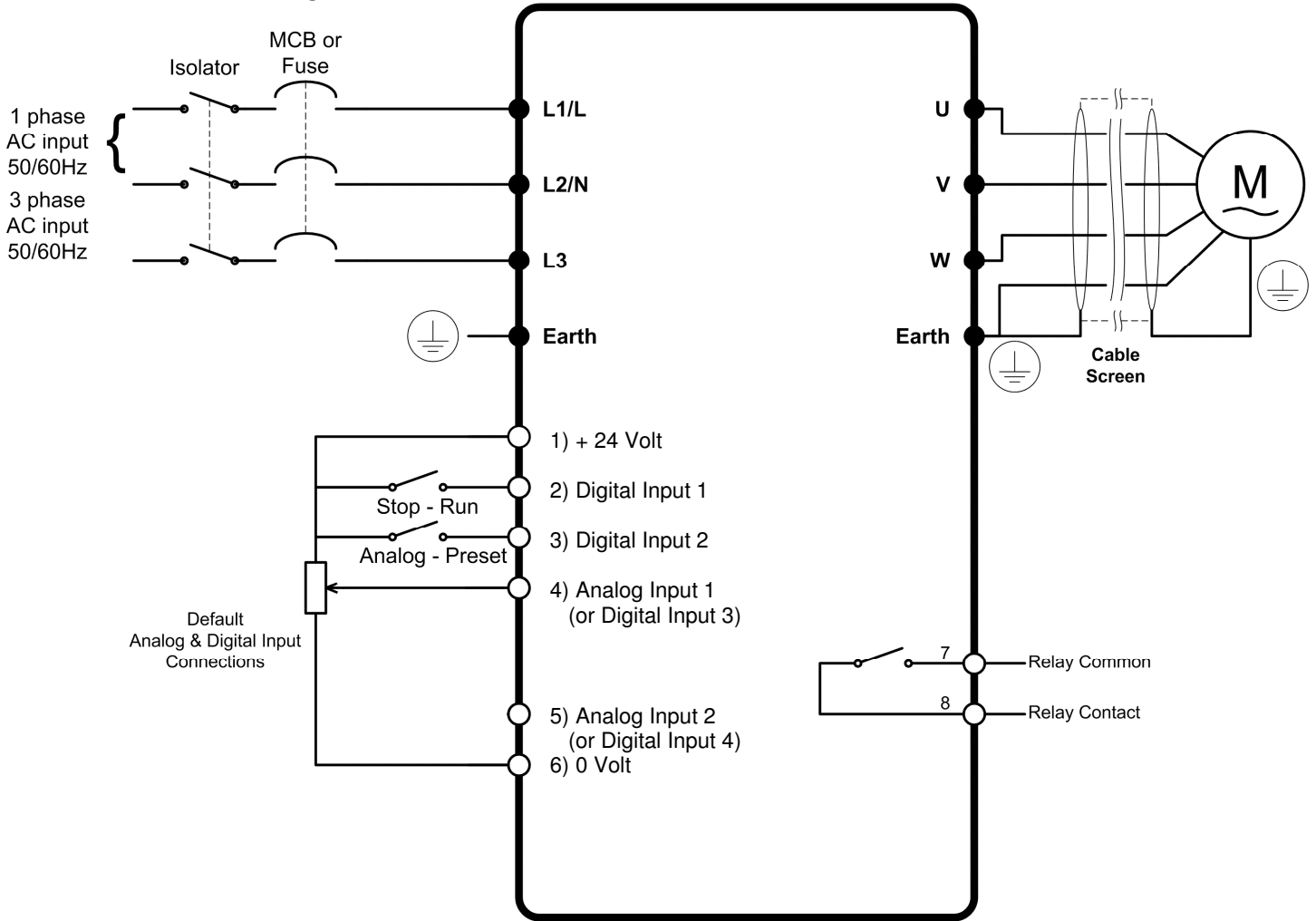

4.4. Drive and motor connections

For 1 phase supply power should be connected to L1/L, L2/N.

For 3 phase supplies power should be connected to L1, L2, and L3. Phase sequence is not important.

Motor should be connection to U, V, and W

For drives that have a dynamic brake transistor, an optional external braking resistor can be connected to +DC and BR when required. The brake resistor circuit should be protected by a suitable thermal protection circuit.

4.5. Motor Terminal Box Connections

Most general purpose motors are wound for operation on dual voltage supplies. This is indicated on the nameplate of the motor

This operational voltage is normally selected when installing the motor by selecting either STAR or DELTA connection. STAR always gives the higher of the two voltage ratings.

Incoming Supply Voltage	Motor Nameplate Voltages		Connection
230	230 / 400	Delta	DELTA Δ
400	400 / 690		
400	230 / 400	Star	STAR \star

4.6. Control terminal connections

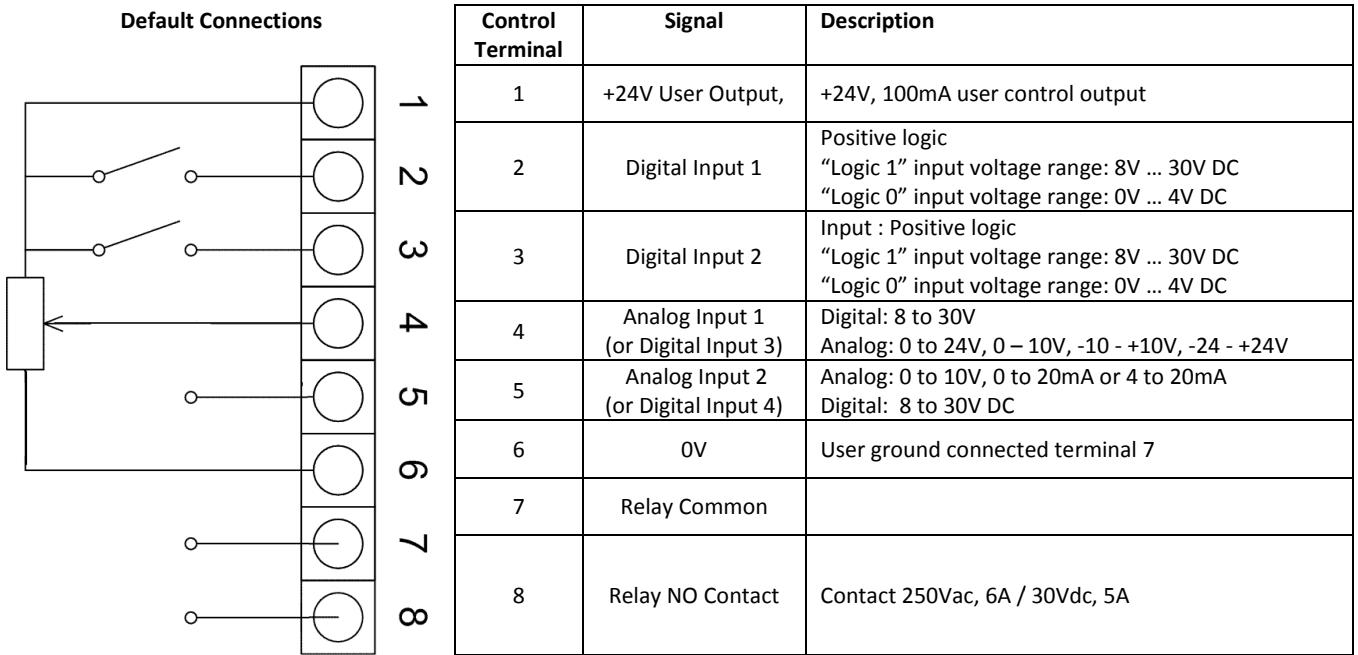









5. Operation

The drive should be configured prior to first operation via the optionally available Optiport Plus remote keypad, or Optiwand PDA Pocket PC software.

























5.1. Optional Optiport Plus Keypad

	NAVIGATE	Used to display real-time information, to access and exit parameter edit mode and to store parameter changes
	UP	Used to increase speed in real-time mode or to increase parameter values in parameter edit mode
	DOWN	Used to decrease speed in real-time mode or to decrease parameter values in parameter edit mode
	RESET / STOP	Used to reset a tripped drive. When in Keypad mode is used to Stop a running drive.
	START	When in keypad mode, used to Start a stopped drive or to reverse the direction of rotation if bi-directional keypad mode is enabled





5.2. Changing Parameters

Procedure	Display shows...
Power on Drive	StoP
Press and hold the  for >2 seconds	P 1-01
Press the  Key	P 1-02
The  and  can be used to select the desired parameter	P 1-03 etc...
Select the required parameter, e.g. P1-02	P 1-02
Press the  button	0.0
Use the  and  keys to adjust the value, e.g. set to 10	10.0
Press the  key	P 1-02
The parameter value is now adjusted and automatically stored. Press the  key for >2 seconds to return to operating mode	StoP

5.3. Advanced Keypad Operation Short Cuts



Function	When Display shows...	Press...	Result	Example
Fast Selection of Parameter Groups Note : Parameter Group Access must be enabled P1-14 = 101	Px-xx	 + 	The next highest Parameter group is selected	Display shows P 1- 10 Press  +  Display shows P2-01
	Px-xx	 + 	The next lowest Parameter group is selected	Display shows P2-26 Press  +  Display shows P 1-01
Select lowest Group Parameter	Px-xx	 + 	The first parameter of a group is selected	Display shows P 1- 10 Press  +  Display shows P 1-01
Set Parameter to minimum value	Any numerical value (Whilst editing a parameter value)	 + 	The parameter is set to the minimum value	When editing P1-01 Display shows 50.0 Press  +  Display shows 0.0
Adjusting individual digits within a parameter value	Any numerical value (Whilst editing a parameter value)	 + 	Individual parameter digits can be adjusted	When editing P1-10 Display shows 0 Press  +  Display shows .0 Press  Display shows 10 Press  +  Display shows . 10 Press  Display shows 1 10 Etc...

5.4. Reset All Parameters to Factory Default Settings

To reset all drive parameters to factory default settings, press ,  and  for >2s. The display shows **P-dEF**. Press the  button to acknowledge and reset the drive.















5.5. Terminal Control

When delivered, the Optidrive is in the factory default state, meaning that it is set to operate in terminal control mode and all parameters have the default values as indicated in section 6 Parameters.

- Connect the drive to the supply, ensuring the correct voltage and fusing / circuit breaker protection – see section 2.2 on page 5.
- Connect the motor to the drive, ensuring the correct star/delta connection for the voltage rating - see section 0 on page 8.
- Enter the motor data from motor nameplate; P1-07 = motor rated voltage, P1-08 = motor rated current, P1-09 = motor rated frequency.
- Connect a control switch between the control terminals 1 and 2 ensuring that the contact is open (drive disabled).
- Connect a potentiometer (1kΩ min to 10 kΩ max) between terminals 5 and 7, and the wiper to terminal 6.
- With the potentiometer set to zero, switch on the supply to the drive. The display will show **StoP**.
- Close the control switch, terminals 1-2. The drive is now 'enabled' and the output frequency/speed are controlled by the potentiometer.
- On first enable from factory default parameters, the Optidrive will carry out an Autotune, and the display shows **Auto-t**. Leave the control switch closed and allow this to complete.
- Following completion of the Autotune, the display shows zero speed in Hz (**H 0.0**) with the potentiometer turned to minimum.
- Turn the potentiometer to maximum. The motor will accelerate to 50Hz, (60Hz for USA drives), the default value of P1-01, under the control of the acceleration ramp time P1-03. The display shows 50Hz (**H 50.0**) at max speed.
- If the potentiometer is turned to minimum, the motor will decelerate to 0Hz, the default minimum speed set in P1-02, under the control of the deceleration ramp P1-04. The output speed can be adjusted anywhere between minimum and maximum speed using the potentiometer.
- To display motor current (Amps), briefly press the  (Navigate) key.
- Press  again to display the motor power.
- Press  again to return to speed display.
- To stop the motor, disable the drive by opening the control switch (terminals 1-2).
- If the enable/disable switch is opened the drive will decelerate to stop at which time the display will show **StoP**.

5.6. Keypad Control

To allow the Optidrive to be controlled from the keypad in a forward direction only, set P1-12 =1:

- Connect the supply and motor as for terminal control above.
- Enable the drive by closing the switch between control terminals 1 & 2. The display will show **StoP**.
- Press the  key. If this is the first enable from factory default parameters, the drive will carry out an Autotune as described above. On completion of the Autotune, the display shows **H 0.0**.
- Press  to increase speed.
- The drive will run forward, increasing speed until  is released.
- Press  to decrease speed. The drive will decrease speed until  is released. The rate of deceleration is limited by the setting in P1-04
- Press the  key. The drive will decelerate to rest at the rate set in P1-04.
- The display will finally show **StoP** at which point the drive is disabled
- To preset a target speed prior to enable, press the  key whilst the drive is stopped. The display will show the target speed, use the  &  keys to adjust as required then press the  key to return the display to **StoP**.
- Pressing the  key will start the drive accelerating to the target speed.
- To allow the Optidrive to be controlled from the keypad in a forward and reverse direction, set P1-12 =2:
- Operation is the same as when P1-12=1 for start, stop and changing speed.
- Press the  key. The display changes to **H 0.0**.
- Press  to increase speed
- The drive will run forward, increasing speed until  is released. Acceleration is limited by the setting in P1-03. The maximum speed is the speed set in P1-01.
- To reverse the direction of rotation of the motor, press the  key again.

5.1. Motor Autotuning

Optidrive Plus uses a sophisticated Voltage Vector Control Method as a factory default setting to ensure best possible motor operation. This control method requires the Optidrive to carry out an autotune to measure certain motor parameters prior to operation, to ensure this function operates correctly, and reduce the risk of nuisance tripping.



Whilst the autotune procedure does not drive or spin the motor, the motor shaft may still turn. It is not normally necessary to uncouple the load from the motor; however the user should ensure that no risk arises from the possible movement of the motor shaft.

Autotune after Factory Reset or from Factory Set Parameters

Following a factory reset (See section 5.4), the correct data from the motor nameplate should be entered in P1-07 (Motor Rated Voltage), P1-08 (Motor Rated Current) and P1-09 (Motor Rated Frequency). Providing that P1-08 is adjusted from the factory default setting, the Optidrive will automatically carry out an autotune on the motor the first time it is enabled. During the autotune, the display will show **Auto-t**. The test procedure may take several minutes to complete depending on the motor. Once the autotune is completed, the drive will operate as normal, and no further autotuning will be required unless the motor or drive control mode is changed (P4-01).

User Selected Autotune

The user can program the drive to carry out an autotune if required, as follows:-

Ensure the motor nameplate values are correctly entered as described above.

Set P1-14 = 101 to allow access to Parameter Groups 2, 3 and 4

Set P4-02 = 1 and press the  button.



The autotune will begin immediately when P4-02 is set to 1, and no external enable signal is required. During the autotune procedure, the motor shaft may turn. It is not normally necessary to uncouple the load from the motor; however the user should ensure that no risk arises from the possible movement of the motor shaft.

5.2. Operating in Sensorless Vector Speed Control Mode

Optidrive Plus can be programmed by the user to operate in Sensorless Vector mode, which provides enhanced low speed torque, optimum motor speed regulation regardless of load and accurate control of the motor torque. In most applications, the default Voltage Vector control mode will provide adequate performance, however if Sensorless Vector operation is required, the following procedure should be followed:-

Ensure the motor nameplate values are correctly entered in P1-07 (Motor Rated Voltage), P1-08 (Motor Rated Current) and P1-09 (Motor Rated Frequency)

Set P1-14 = 101 to allow access to parameter groups 2, 3 and 4

The Motor Rated Power Factor from the motor nameplate **MUST** be entered in P4-05. If this data is not available, consult the motor manufacturer for guidance.

Set P4-01 = 0 to select Sensorless Vector Speed Control

Set P4-02 = 1 to carry out an motor autotune

Parameters P4-03 and P4-04 have a significant effect on the behaviour of the motor when operating in vector mode, see section 6.4 for further details, or the Optidrive Advanced User Guide.



The autotune will begin immediately when P4-02 is set to 1, and no external enable signal is required. During the autotune procedure, the motor shaft may turn. It is not normally necessary to uncouple the load from the motor; however the user should ensure that no risk arises from the possible movement of the motor shaft.

5.3. Sensorless Vector Torque Control Mode

For applications which require the drive to control motor torque as opposed to motor speed, the Optidrive Plus can be programmed to operate in Torque Control mode. When operating this way, the drive internal ramp times (P1-03 and P1-04) are disabled except during starting and stopping. Please refer to the Optidrive Plus Advanced User Guide for further information on this.

6. Parameters

6.1. Parameter Group 1 – Basic Parameters

Par.	Description	Range	Units	Default	Explanation
P1-01	Maximum Frequency / Speed	P-02 to 5*P-09 (max 2000Hz)	Hz Rpm	50.0 (60.0)	Maximum speed limit – Hz or rpm. If P1-10 >0, the value entered is in Rpm
P1-02	Minimum Frequency / Speed	0.0 to P-01 (max 500Hz)	Hz Rpm	0.0Hz	Minimum speed limit – Hz or rpm. If P1-10 >0, the value entered is in Rpm
P1-03	Acceleration ramp time	0.0 to 3000.0	seconds	5.0	Acceleration ramp time from 0 to base speed (P1-09) in seconds
P1-04	Deceleration ramp time	0.0 to 3000.0	seconds	5.0	Deceleration ramp time from base speed (P1-09) to standstill in seconds. When set to zero, fastest possible ramp time without trip is activated
P1-05	Stop mode select	0 : Ramp stop (brown-out ride-through) 1 : Coast to stop 2 : Ramp to stop (fast stop)	-	0	0 : If the mains supply is lost, the drive will try to continue running by reducing the speed of the load using the load as a generator. 1 : When the enable signal is removed from the drive, the motor will coast (freewheel) to stop 2 : If the mains supply is lost, the drive will ramp to stop using the P2-25 decel ramp time
P1-06	Energy Optimiser	0: Disabled 1: Enabled	-	0	When enabled, automatically reduces applied motor voltage on light load. Minimum value is 50% of nominal
P1-07	Motor rated voltage	0, 20 to 250 0, 20 to 500	Volts	230 400 (460)	Rated (nameplate) voltage of the motor (Volts). Value limited to 250V for low voltage drives. Setting to zero disables voltage compensation
P1-08	Motor rated current	25% -100% of drive rated current	Amps	Drive rating	Rated (nameplate) current of the motor
P1-09	Motor rated frequency	25Hz to 500Hz	Hz	50 (60)	Rated (nameplate) frequency of the motor
P1-10	Motor rated speed	0 to 30 000 rpm	Rpm	0	When non-zero, all speed related parameters are displayed in rpm
P1-11	Preset Speed 1	-P1-01 to P1-01	Hz	50 (60)	Sets the speed the drive runs at when Preset Speed 1 is selected
P1-12	Terminal / Keypad / PID Drive Control Mode Selection	0.Terminal control 1. Keypad control – fwd only 2. Keypad control – fwd and rev 3. PID Control	-	0	Primary Control Mode of the drive. 0 : Terminal control 1 : Uni-directional keypad control. Keypad START button does not reverse direction. 2 : Bi-directional keypad control. Keypad START button toggles between forward and reverse. 3 : User PI control with external feedback signal
P1-13	Trip log	Last four trips stored	-	Read only	Previous 4 trips stored in order of occurrence, with the most recent first. Press UP or DOWN to step through all four. The most recent trip is always displayed first. UV trip is only stored once.
P1-14	Extended menu access	Code 0 to 9 999	-	0	Set to "101" (default) for extended menu access. Change code in P2-37 to prevent unauthorised access to the Extended Parameter Set

NOTE Default parameter values for Horse Power rated drives are shown in brackets

Following a factory reset, or when installing a drive for the first time, only Group 1 Parameter access is available. To allow access to Parameters Groups 0, 2, 3 and 4, Parameters P1-14 and P2-37 must contain the same value. The factory set value for P2-37 = 101

6.2. Parameter Group 2 - Extended parameters

Par.	Description	Range	Units	Default	Explanation
P2-01	Digital input function select	0 to 22	-	0	Defines the function of the digital inputs depending on the control mode setting in P-12. See section 7 Analog and Digital Input Configurations for more information.
P2-02	Preset Speed 2	-P1-01 to P1-01	Hz	0.0	Sets jog / preset speed 2
P2-03	Preset Speed 3	-P1-01 to P1-01	Hz	0.0	Sets jog / preset speed 3
P2-04	Preset Speed 4	-P1-01 to P1-01	Hz	0.0	Sets jog / preset speed 4
P2-05	Preset Speed 5	-P1-01 to P1-01	Hz	0.0	Sets jog / preset speed 5
P2-06	Preset Speed 6	-P1-01 to P1-01	Hz	0.0	Sets jog / preset speed 6
P2-07	Preset speed 7	-P1-01 to P1-01	Hz	0.0	Sets jog / preset speed 7
P2-08	Preset speed 8	-P1-01 to P1-01	Hz	0.0	Sets jog / preset speed 8
P2-09	Skip frequency	P1-02 to P1-01	Hz	0.	Centre point of skip frequency band set up in conjunction with P2-10
P2-10	Skip frequency band	0.0 to P1-01	Hz	0.0	Width of skip frequency band centred on frequency set in P2-09
P2-11	Reserved				
P2-12	Reserved				
P2-13	User Relay Output Function Select	0 : Drive enabled 1 : Drive healthy 2 : Motor at target speed 3 : Motor Speed >0 4 : Motor speed >= limit 5 : Motor torque >= limit 6 : 2 nd Analog Input >= limit		1	Selects the function assigned to the relay output. 0 : Logic 1 when the drive is enabled (Running) 1 : Logic 1 When no Fault condition exists on the drive 2 : Logic 1 when the motor speed matches the setpoint speed 3 : Logic 1 when the motor runs above zero speed Options 4 to 6 : the Digital output is enabled using the level set in P2-14h and P2-14L
P2-14h	Relay Output Control High Limit	0.0 to 200.0	%	100.0	With P2-13 = 4 to 6, the User Relay Output is set to Logic 1 (+24V DC) when the value set in P2-14h is exceeded, and returns to Logic 0 (0V) when the selected value reduces below the limit set in P2-12L
P2-14L	Relay Output Control Low Limit	0.0 to 200.0	%	100.0	
P2-15	Relay Output Mode	0 : Normally Open 1 : Normally Closed	-	0	Inverts the operating status of the User Relay 0 : Logic 1 = Relay Contacts Closed 1 : Logic 1 = Relay Contacts Open The drive must be powered for the contacts to close
P2-16	Zero Speed Holding Time	0.0 to 60.0	s	0.2	Determines the time for which the drive output is held at zero speed when stopping, before the drive output is disabled
P2-17	Start Mode Select	Edge-r Auto-0 Auto-1 to 5	-	Auto-0	Edge-r : Following Power on or reset, the drive will not start if Digital Input 1 remains closed. The Input must be closed following a power on or reset to start the drive. Auto-0 : Following a Power On or Reset, the drive will automatically start if Digital Input 1 is closed. Auto 1 to 5 : Following a Fault, the drive will make up to 5 attempts to restart at 20 second intervals. The drive must be powered down to reset the counter
P2-18	Reserved		-	-	No Function

Par.	Description	Range	Units	Default	Explanation
P2-19	Keypad Restart Mode	0 : Minimum Speed, Edge-r 1 : Previous Speed, Edge-r 2 : Minimum Speed, Auto-r 3: Previous Speed, Auto-r	-	0	Active when P1-12 = 1 or 2 0 : Following a stop and restart, the drive will run at minimum speed 1 : Following a stop and restart, the drive will run at the last setpoint speed 2 : As per setting 0, except that the Run command will be determined by the status of Digital Input 1, and the user is not required to press the keypad start button 3 : As per setting 1, except that the Run command will be determined by the status of Digital Input 1, and the user is not required to press the keypad start button
P2-20	Standby Mode	0.0 : Disabled 0.1 to 60	seconds	0.0	When P2-20 >0, the drive enters standby mode if the minimum speed is maintained for the time period set in P2-20
P2-21	Display Scaling Factor	0.000 to 30.000	-	0.000	Disabled if P2-21 is set to 0. If P2-21 is set >0, the variable selected in P2-22 is multiplied by the factor entered in P2-21, and displayed whilst the drive is running
P2-22	Display Scaling Source	0 : 2 nd Analog Input 1 : Motor Speed 2 : Motor Torque 3 : Motor Current	-	0	
P2-24	Effective Switching Frequency	4 to 16 / 24 / 32 Drive Power Rating Dependent	kHz	16 8 4	Effective power stage switching frequency. Higher frequencies reduce the audible 'ringing' noise from the motor, and improve the output current waveform, at the expense of increased drive losses
P2-25	2 nd Deceleration Ramp time	0.0 to 30.0	seconds	0.0	Deceleration 2 nd ramp down time Selected Automatically on mains power loss if P1-05 = 2 Can also be selected by digital inputs, dependent on P2-01 setting. When set to 0, the drive decelerates as quickly as possible, whilst preventing an overvoltage trip
P2-26	Communication Baud Rate	0 : Automatic	-	0	Factory set serial data link communication Baud Rate
P2-27	Drive Communication Address	0: Disabled 1 to 63	-	1	Sets the communication address for the drive when connected on an Optibus Network
P2-28	Master / Slave Mode Select	0 : Slave Mode 1 : Master Mode	-	0	When in Master Mode, the drive transmits its operational status via the serial data link. All drives on the data link must have unique addresses. Only one drive can be programmed as a Master
P2-29	Digital / Slave speed reference scaling factor	0 to 500.0	%	100.0	Scaling factor applied to any speed reference on the serial data link, e.g. in Master / Slave operation, a Slave drive will apply this scaling factor to the transmitted Master speed reference
P2-30	Analog Input 1 format	U 0-24 = 0 - 24V DC U 0- 10 = 0 - 10V DC	-	U 0-24	Configures the analog input signal to match the reference connected to terminal 6. Only voltage signals can be directly connected, mA reference signals require an external resistor connection.
P2-31	Analog Input 1 scaling	0 to 500.0	%	100.0	Scales the analog input by this factor, e.g. if P2-30 is set for 0 – 10V, and the scaling factor is set to 200.0%, a 5 volt input will result in the drive running at maximum speed (P1-01)
P2-32	Analog Input 1 offset	-500.0 to 500.0	%	0.0	Sets an offset, as a percentage of the full scale range of the input, which is applied to the analog input signal
P2-33	Analog Input 2 format	d 0-24 = Digital U 0- 10 = 0 to 10V DC A 4-20 = 4 to 20mA A0-20 = 0 to 20mA	-	d 0-24	Selects the format for the 2 nd analog input Selecting d 0-24 sets the input up as a digital input
P2-34	Analog Input 2 scaling	0 to 500.0	%	100.0	Scales the 2 nd analog input by the factor set in this parameter

Par.	Description	Range	Units	Default	Explanation
P2-35	Digital speed reference scaling control	0 : Disabled (No Scaling) 1 : Scaled by P2-29 2 : Scaled by P2-29, then bipolar analog input added as an offset 3 : Scaled by P2-29 <i>and</i> by bipolar analog input	-	0	Active in Keypad mode (P1-12 = 1 or 2) and Master / Slave mode only. 1 : Actual Speed = Digital Speed x P2-29 2 : Actual Speed = (Digital Speed x P2-29) + bipolar analog reference 3 : Actual Speed = Digital Speed x P2-29 x bipolar analog reference
P2-36	Reserved		-	-	No Function
P2-37	Extended menu access code	0 to 9999	-	101	Defines the access code which must be entered in P1-14 to access parameter groups above Group 1
P2-38	Parameter Lock	0 : Unlocked 1 : Locked	-	0	When locked, all parameter changes are prevented
P2-39	Hours Run Counter	0 to 99999	Hours	-	Indicates the number of hours for which the drive has run
P2-40	Drive Type / Rating	N/A	-	-	Read only parameter, showing the drive type and power rating

6.3. Parameter Group 3 – PID Control

Par.	Description	Range	Units	Default	Explanation
P3-01	Proportional gain	0.1 to 30.0	-	2.0	PID Controller Proportional Gain. Higher values provide a greater change in the drive output frequency in response to small changes in the feedback signal. Too high a value can cause instability
P3-02	Integral time constant	0.0 to 30.0	seconds	1.0	PID Controller Integral Time. Larger values provide a more damped response for systems where the overall process responds slowly
P3-03	Differential time constant	0.00 to 1.0	seconds	0.00	D means don't ever set this
P3-04	PID operating mode	0 : Direct 1 : Inverse	-	0	Direct operation – Motor speed <i>increases</i> with an increase in the feedback signal Inverse Operation – Motor speed <i>decreases</i> with an increase in the feedback signal
P3-05	PID Setpoint / reference select	0 : Digital 1 : Analog	-	0	Selects the source for the PID Reference / Setpoint 0 : P3-06 is used 1 : Bipolar analog input is used
P3-06	PID digital reference	0.0 to 100.0	%	0.0	Sets the preset digital PID reference / setpoint
P3-07	PID controller high limit output	P3-08 to 100.0	%	100.0	Limits the maximum value output from the PID controller
P3-08	PID controller low limit output	0.0 to P3-07	%	0.0	Limits the minimum output from the PID controller
P3-09	User PID output limit / function control	0 : Digital output limits 1 : Analog Upper Limit 2: Analog Lower Limit 3 : PID added to Bipolar analog input reference	-	0	0 : PID output range limited by P3-07 & P3-08 1 : PID maximum output limited by the signal applied to the bipolar analog input 2: PID minimum output limited by the signal applied to the bipolar analog input 3: PID output is added to the speed reference applied to the bipolar analog input
P3-10	PID feedback source select	0 : 2 nd Analog Input 1 : Bipolar analog input	-	0	Selects the source of the PID feedback signal

6.4. Parameter Group 4 – High Performance Motor Control

Par.	Description	Range	Units	Default	Explanation
P4-01	Control Mode	0 : Vector Speed Control 1 : Vector Torque Control 2 : V/F Speed Control	-	2	Selects the motor control method. An autotune must be performed following a change, see section 6.4
P4-02	Motor parameter autotune	0 : Disabled 1 : Enabled	-	0	When set to 1, the drive immediately carries out a non-rotating autotune to measure the motor parameters for optimum control and efficiency
P4-03	Speed controller proportional gain	0 to 4096	-	300	Sets the proportional gain value for the speed controller. Higher values provide better output frequency regulation and response. Too high a value may cause instability
P4-04	Speed controller integral time	0.050 to 1.000	seconds	0.050	Set the integral time for the speed controller. Smaller values provide a faster response in reaction to motor load changes, at the risk of introducing instability
P4-05	Motor power factor	0.50 to 1.00	-	-	Motor nameplate power factor, which must be entered for Vector operation (P4-01 = 0 or 1)
P4-06	Torque reference source select	0 : Preset Value 1 : Bipolar analog input 2 : 2 nd analog input	-	0	When operating in vector mode (P4-01 = 0 or 1), selects the source of the torque reference
P4-07	Maximum torque limit / torque reference	0.0 to 200.0	%	200.0	If P4-01 = 1 and P4-06 = 0, sets the preset torque reference If P4-01 = 0, sets the maximum torque limit
P4-08	Minimum torque limit	0.0 to 150.0	%	0.0	Sets a minimum torque limit, see the warning below
P4-09	V/F characteristic adjustment frequency	0.0 to P1-09	Hz	0.0	When operating in V/F mode (P4-01 = 2), sets a frequency point at which the voltage applied in P4-10 is applied to the motor. Care must be taken to avoid over heating and damaging the motor when using this feature
P4-10	V/F characteristic adjustment voltage	0 to P1-07	-	0	In conjunction with P4-09, in V/F mode (P4-01 = 2), sets the voltage applied to the motor at the adjustment frequency set in P4-09

Incorrect adjustment of parameters in menu group 4 can cause unexpected behaviour of the motor and any connected machinery. It is recommended that these parameters are only adjusted by experienced users

6.5. Parameter Group 0 – Monitoring Parameters (Read Only)

Par.	Description	Display range	Units	Explanation
P0-01	Bipolar analog input value	0 to 100	%	100% = max input voltage
P0-02	2nd Analog input value	0 to 100	%	100% = max input voltage
P0-03	Post Ramp Speed Reference	-500 to 500	%	100% = P1-09
P0-04	Digital speed reference	-P1-01 to P1-01	Hz / Rpm	Digital speed reference
P0-05	Torque controller reference	0 to 200	%	Torque reference setpoint
P0-06	PID Reference	0 to 100	%	PID reference / setpoint
P0-07	PID Feedback	0 to 100	%	PID controller feedback value
P0-08	PID error	0 to 100	%	Actual PID error
P0-09	PID P Term	0 to 100	%	Proportional component
P0-10	PID I term	0 to 100	%	Integral component
P0-11	PID D term	0 to 100	%	Differential component
P0-12	PID Output	0 to 100	%	Output from PID controller
P0-13	Output Torque	0 to 200	%	100% = motor rated torque
P0-14	Magnetising current	Drive dependent	A	Motor rms magnetising current
P0-15	Rotor Current	Drive dependent	A	Rotor rms current
P0-16	Field Strength	0 to 100	%	Magnetic field strength
P0-17	Stator resistance	Drive dependent	Ohms	Phase to phase stator resistance
P0-18	Stator Inductance	Drive dependent	H	Stator inductance
P0-19	Rotor resistance	Drive dependent	Ohm	Calculated rotor resistance
P0-20	DC Bus Voltage	0 to 1000	Volts	Internal DC Bus voltage
P0-21	Drive Temperature	0 to 120	°C	Measured heatsink temperature
P0-22	Supply voltage L1 – L2	Drive dependent	Volts	Phase to phase supply voltage
P0-23	Supply voltage L2 – L3	Drive dependent	Volts	Phase to phase supply voltage
P0-24	Supply voltage L3 – L1	Drive dependent	Volts	Phase to phase supply voltage
P0-25	Estimated rotor speed	Drive dependent	Hz / Rpm	In vector mode, estimated speed of motor
P0-26	kWh meter	0 to 999.9	kWh	Cumulative energy consumption
P0-27	MWh meter	0 to 60,000	MWh	Cumulative energy consumption
P0-28	Software ID – IO Processor	Drive dependent	-	Version number & checksum
P0-29	Software ID – Motor Control	Drive dependent	-	Version number & checksum
P0-30	Drive serial number	Drive dependent	-	Unique drive serial number

7. Analog and Digital Input Configurations



7.1. Terminal mode (P1-12 =0)



P2-01	Digital input 1 (T2)	Digital input 2 (T3)	Analog Input 1 (T4) (or Digital Input 3)	Analog input 2 (T5) (or Digital Input 4)	
0	Open: Stop (disable) Closed: Run (enable)	Open : Bipolar analog speed ref Closed : Preset speed ref	Bipolar Analog Input	Open : Preset Speed 1 Closed : Preset Speed 2	
1	Open: Stop (disable) Closed: Run (enable)	Open: Preset Speed 1 Closed: Preset speed 2	Open : Preset Speed 1 / 2 / 3 Closed : Preset Speed 4	Open : Preset Speed 1 / 2 Closed : Preset Speed 3	
2	Open: Stop (disable) Closed: Run (enable)	Digital Input 2	Digital Input 3	Digital Input 4	Speed Setpoint
		Open	Open	Open	Preset Speed 1
		Closed	Open	Open	Preset Speed 2
		Open	Open	Closed	Preset Speed 3
		Closed	Open	Closed	Preset Speed 4
		Open	Closed	Open	Preset Speed 5
		Closed	Closed	Open	Preset Speed 6
3	Open: Stop (disable) Closed: Run (enable)	Open : Forward Closed : Reverse	Bipolar Analog Input	Open: Bipolar analog ref Closed: Preset Speed 1	
		Open : Forward Closed : Reverse	Bipolar Analog Input	Analog input 2 (E.g. Torque reference)	
5	Open: Stop (disable) Closed: Run (enable)	Open : Forward Closed : Reverse	Digital Input 3	Digital Input 4	Speed Setpoint
			Open	Open	Preset Speed 1
			Open	Closed	Preset Speed 2
			Closed	Open	Preset Speed 3
6	Open: Stop (disable) Closed: Run (enable)	Open : Forward Closed : Reverse	Bipolar Analog Input	External trip input : Open: Trip, Closed: No Trip	
				7	Open: Stop (disable) Closed: Fwd Run (enable)
8	Open: Stop (disable) Closed: Fwd Run (enable)	Open: Stop (disable) Closed: Rev Run (enable)	Bipolar Analog Input		
				9	Open: Stop (disable) Closed: Forward Run (enable)
Open	Open	Preset Speed 1			
Open	Closed	Preset Speed 2			
Closed	Open	Preset Speed 3			
10	Open: Stop (disable) Closed: Forward Run (enable)	Open: Stop (disable) Closed: Reverse Run (enable)	Bipolar Analog Input	External trip input : Open: Trip, Closed: No Trip	
				11	Open: Stop (disable) Closed: Run (enable)
12	Open: Stop (disable) Closed: Run (enable)	Open : Preset Speed 1 Closed : Bipolar analog speed ref	Bipolar Analog Input		
				13	Normally Open (NO) Momentarily Close to Run
14	Normally Open (NO) Momentarily Close to Run Fwd	Normally Closed (NC) Momentarily Open to Stop	Bipolar Analog Input		
				15	Open: Stop (disable) Closed: Run (enable)
16	Open: Stop (disable) Closed: Run (enable)	Open : Forward Closed : Reverse	Open: Preset Speed 1 Closed: Preset Speed 2		
				17	Normally Open (NO) Momentarily Close to Run Fwd
18	Open: Stop (disable) Closed: Run (enable)	Digital Input 2	Digital Input 4		
		Open	Open	Preset Speed 1	
		Closed	Open	Preset Speed 2	
		Open	Closed	Preset Speed 3	
19	Open: Stop (disable) Closed: Run (enable)	Open : Bipolar analog speed ref Closed : Analog input 2 speed ref	Bipolar Analog Input	Analog input 2	
				20	Open: Stop (disable) Closed: Run (enable)
21	Open: Stop (disable) Closed: Run (enable)	No Function	Bipolar Analog Input		
				22	Open: Stop (disable) Closed: Run (enable)
NOTE	Negative Preset Speeds will be inverted if Run Reverse selected. The external trip input can be used to connect a motor thermistor by connecting the thermistor between terminals 1 and 4				

7.2. Keypad mode (P1-12 = 1 or 2)

P2-01	Digital input 1 (T2)	Digital input 2 (T3)	Analog Input 1 (T4) (or Digital Input 3)	Analog input 2 (T4) (or Digital Input 4)	
0	Open: Stop (disable) Closed: Run (enable)	Closed : remote UP push-button	No Function	Closed : remote DOWN push-button	
1	Open: Stop (disable) Closed: Run (enable)	Closed : remote UP push-button	Closed : remote DOWN push-button	External trip input : Open: Trip, Closed: No Trip	
2	Open: Stop (disable) Closed: Run (enable)	Closed : remote UP push-button	Open : Forward Closed : Reverse	Open : Digital speed ref Closed: Preset speed 1	
3..9, 13, 14 & 16	Open: Stop (disable) Closed: Run (enable)	Closed : remote UP push-button	Open : Forward Closed : Reverse	Closed : remote DOWN push-button	
10	Open: Stop (disable) Closed: Run (enable)	Open : Digital speed ref Closed : Bipolar analog speed ref	Bipolar Analog Input	External trip input : Open: Trip, Closed: No Trip	
11	Open: Stop (disable) Closed: Run (enable)	Open : Digital speed ref Closed : Preset speed 1	Open : Forward Closed : Reverse	External trip input : Open: Trip, Closed: No Trip	
12	Open: Stop (disable) Closed: Run (enable)	Open : Preset speed 1 Closed : Digital speed ref	Open : Forward Closed : Reverse	External trip input : Open: Trip, Closed: No Trip	
15	Open: Stop (disable) Closed: Run (enable)	Open : Digital speed ref Closed : Preset speed 1	Open : Forward Closed : Reverse	Open: Decel Ramp 1 (P1-04) Closed: Decel Ramp 2 (P2-25)	
17	Open: Stop (disable) Closed: Run (enable)	Open : Digital speed ref Closed : Bipolar analog speed ref	Bipolar Analog Input	Open : Digital / Analog ref Closed : Preset speed 1	
18	Open: Stop (disable) Closed: Run (enable)	Open : Digital speed ref Closed : Preset speed ref	Digital Input 3	Digital Input 4	Preset reference
			Open	Open	Preset Speed 1
			Open	Closed	Preset Speed 2
			Closed	Open	Preset Speed 3
19	Open: Stop (disable) Closed: Run (enable)	Open : Digital speed ref Closed : Analog input 2 ref	Open : Forward Closed : Reverse	Analog input 2	
20, 21	Open: Stop (disable) Closed: Run (enable)	No Function	Open : Forward Closed : Reverse	Open : Digital speed ref Closed : Preset speed 1	
22	Open: Stop (disable) Closed: Run (enable)	No Function	Open : Forward Closed : Reverse	External trip input : Open: Trip, Closed: No Trip	

NOTE

By default, if the enable signal is present the drive will not Enable until the  button is pressed. To automatically enable the drive when the enable signal is present set P2-19 = 2 or 3. This then disables the use of the  &  buttons

In keypad mode, the speed can be adjusted using the  &  keys on the built in keypad, or a remote mounted Optiport Plus keypad, in addition to pushbuttons connected to the digital inputs

The reverse input only functions under the following conditions

- P1-12 = 1, P2-19 = 2 or 3. P2-35 must not be 2 or 3
- P1-12 = 2. P 2-35 must not be 2 or 3

The external trip input can be used to connect a motor thermistor by connecting the thermistor between terminals 1 and 4

7.3. User PI control mode (P1-12 = 3)

P2-01	Digital input 1 (T2)	Digital input 2 (T3)	Analog Input 1 (T4) (or Digital Input 3)	Analog input 2 (T4) (or Digital Input 4)
0..10, 13..16, 18	Open: Stop (disable) Closed: Run (enable)	No Function	Bipolar Analog Input	Analog input 2
11	Open: Stop (disable) Closed: Run (enable)	Open : PID control Closed : Preset speed 1	Bipolar Analog Input	External trip input : Open: Trip, Closed: No Trip
12	Open: Stop (disable) Closed: Run (enable)	Open : Preset speed 1 Closed : PID control	Bipolar Analog Input	External trip input : Open: Trip, Closed: No Trip
17	Open: Stop (disable) Closed: Run (enable)	Open : PID Control Closed : Bipolar analog ref	Bipolar Analog Input	Analog input 2
19	Open: Stop (disable) Closed: Run (enable)	Open : PID Control Closed : Analog input 2 ref	Bipolar Analog Input	Analog input 2
20, 21	Open: Stop (disable) Closed: Run (enable)	No Function	Bipolar Analog Input	Analog input 2
22	Open: Stop (disable) Closed: Run (enable)	No Function	Bipolar Analog Input	External trip input : Open: Trip, Closed: No Trip

NOTE

When P3-05 = 1, Bipolar analog input controls PID setpoint. The feedback must then be connected to Analog input 2 and P3-10 must be set to 0 (Default setting)

The external trip input only functions when the feedback source is the Bipolar analog input (P3-10 = 1)

8. Troubleshooting

8.1. Fault messages with optional Optiport Plus Keypad

Fault Code	Description	Corrective Action
P-dEF	Factory Default parameters have been loaded	Press STOP key, drive is ready to configure for particular application
O-I hO-I	Instantaneous over current on drive output. Excess load on the motor. Over temperature on the drive heatsink	If the fault occurs immediately when enabling the drive, disconnect the motor cable from the output terminals of the drive and restart the drive. If the fault re-occurs with no motor connected, contact your local Invertek Sales Partner. If the drive runs correctly with not motor connected, check the motor, motor cable and any connections or junction boxes for phase – phase and phase – earth short circuits. Wherever possible, motors and connection cables should be checked with a high voltage insulation tester (Megga) prior to connection to the drive. Ensure that no switching devices, such as contactors or local isolators are switching during operation of the drive. Check the motor cable length does not exceed the specified maximum Ensure the motor nameplate parameters are correctly entered, P1-07, P1-08, P1-09. If operating in Vector mode (P4-01 – 0 or 1), also check the motor power factor in P4-05. Ensure an autotune has been successfully completed for the connected motor. Check the load mechanically for a jam or stalled condition, or shock loads. Increase the ramp up time in P1-03. If operating in Vector mode (P4-01 – 0 or 1), reduce the speed loop gain in P4-03
I- t- t r P	Drive has tripped on overload after delivering >100% of value in P1-08 for a period of time.	Check to see when the decimal points are flashing (drive in overload) and either increase acceleration rate or reduce the load. Check motor cable length is within spec. Ensure the motor nameplate parameters are correctly entered, P1-07, P1-08, and P1-09. If operating in Vector mode (P4-01 – 0 or 1), also check the motor power factor in P4-05. Ensure an autotune has been successfully completed for the connected motor. Check the load mechanically to ensure it is free, and no jams, blockages or other mechanical faults exist
OI - b	Brake channel over current	Over current in the brake resistor circuit. Check the cabling to the brake resistor. Check the brake resistor value. Ensure minimum resistance values form the rating tables are observed.
OL-br	Brake resistor overload	Brake resistor overload. Increase deceleration time, reduce load inertia or add further brake resistors in parallel, observing the minimum resistance value for the drive in use.
P5- t r P	Fast over current trip	Check wiring to motor, look for ph-ph or ph-Earth short circuit. Check drive ambient temp, additional space or cooling needed? Check drive is not forced into overload.
O_Uo It	Over voltage on DC bus	Supply problem, or increase decel ramp time P-04.
U_Uo It	Under voltage on DC bus	This occurs routinely when power is switched off. If it occurs during running, check power supply voltage.
O-t	Heatsink over temperature	Check drive ambient temp. Additional space or cooling required.
U-t	Under temperature	Trip occurs when ambient temperature is less than 0°C. Temperature must be raised over 0°C in order to start the drive.
t h- F t t	Faulty thermistor on heatsink.	Refer to your IDL Authorised Distributor.
E- t r P	External trip (on digital Input 3)	E-trip requested on digital input 3. Normally closed contact has opened for some reason. If motor thermistor is connected check if the motor is too hot.
4-20 F	4-20mA Input Signal Loss	The level of the 4-20mA signal applied to analog input 2 (Terminal 4) has dropped below the minimum threshold of 3mA. Check for wiring or signal transducer faults
SC- t r P	Comms loss trip	Check communication link between drive and external devices. Make sure each drive in the network has its unique address.
P-LOSS	Input phase loss trip	Drive intended for use with a 3 phase supply has lost one input phase.
Ph-I b	Phase Imbalance	Mains incoming supply voltage has an imbalance of >3% for over 30 seconds. Check incoming supply and fuses
dAtA-F	Internal memory fault.	Parameters not saved, defaults reloaded. Try again. If problem recurs, refer to your local Invertek Sales Partner.
At-F01	Autotune Failed	Measured motor stator resistance varies between phases. Ensure the motor is correctly connected and free from faults. Check the windings for correct resistance and balance.
At-F02		Measured motor stator resistance is too large. Ensure the motor is correctly connected and free from faults. Check that the power rating corresponds to the power rating of the connected drive.
At-F03		Measured motor inductance is too low. Ensure the motor is correctly connected and free from faults.
At-F04		Measured motor inductance is too large. Ensure the motor is correctly connected and free from faults. Check that the power rating corresponds to the power rating of the connected drive.
At-F05		Measured motor parameters are not convergent. Ensure the motor is correctly connected and free from faults. Check that the power rating corresponds to the power rating of the connected drive.
SP in-F	Spin Start Failure	Spin start function (P2-18=1) failed to detect motor speed Check motor and connections. Ensure motor speed is less than maximum speed (P1-01). Make sure motor base frequency (P1-09) is <100Hz



82-OPCS1-IN